

AWEA®

THE ULTIMATE MACHINING POWER



FMV SERIES

5 - axis Gantry Type Machining Centers

Awea Mechantronic Co., Ltd.

INNOVATIVE TECHNOLOGIES FIVE AXIS GANTRY TYPE MACHINING CENTER

AWEA Five Axis Machining Center, FMV series, composed of advanced technologies & high quality machine structure, is capable of handling various applications in 5 axis simultaneous machining with expandable, compact design and at favorable price. FMV series is designed specifically for applications in aerospace, medical technology, 3C industry, die / mold machining in automobile industry and so on. Accuracy, cutting feedrate and table load capability of FMV series is superior than other machines in comparable level. FMV series can fulfill the cutting requirement for nowadays and the future demand as well.



Models	FMV-99	FMV-45	FM-16V
Max. X / Y / Z axes travel	800 / 900 / 660 mm	500 / 450 / 450 mm	500 / 400 / 400 mm
X / Y / Z axes rapids	48 m/min.	48 m/min.	30 m/min.
Spindle motor output	26 kW (con. / 30min)	25 / 29 kW (con. / 30min)	15 / 18.5 kW (con. / 30min)
Max. table load	1,000 Kg	300 Kg	200 Kg
Swiveling range of table	-120° ~ +30°	-180° ~ +160°	-120° ~ +30°
Swiveling / Rotary speed of axis	A-axis : 30 / C-axis : 100 rpm	B-axis : 30 / C-axis : 100 rpm	A-axis : 8.3 / C-axis : 16.7 rpm

Specification are subject to change without notice.

STRENGTH OF ULTIMATE MACHINING PERFORMANCE

Cutting Free Of Collision & Limit

FMV series is able to apply in various 5 axes simultaneous cutting requirement. FMV series provide ample cutting capability in complex curved surface, like "gas turbine blade, propeller and etc" which is not easy to be done in 3 axes machines.

Upgrade Surface Cutting Precision

FMV 5 axes simultaneous cutting can finish free curvature surface, the cutting position and condition is much better than 3 axes machining. Hence, FMV series can give you higher cutting speed, wider cutting path and more precision on free curve surface.

Shorten Cutting Cycle Time

One set up can finish the most of cutting procedure. FMV series give you better cutting efficiency and reduce the possibility of errors which is happened during workpiece movement within different machines.

Extend Tool Life

FMV can extend the tool life since contact surface can be at optimum position instead of the limited position on 3 axes machining.

Save Production Facility Cost

With FMV comprehensive ability to handle various cutting application provides all-in-one cutting solution. No need to buy extra machining center and save precious factory space.

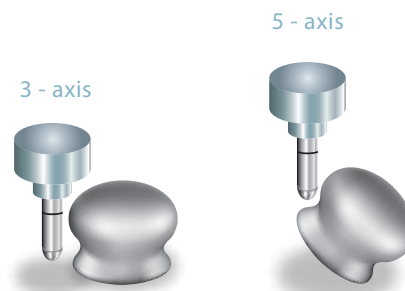
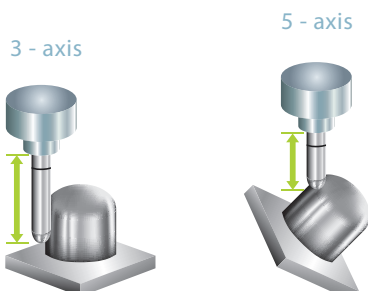

► FMV series can cut side machining with short tool.

► FMV series can cut side-filler machining.

FMV-99 SERIES 5-AXIS MACHINING CENTER

As a high quality 5-axis machine, FMV-99 utilizes U shaped high rigidity structure with dual supported A, C axes rotation table. Combination of 16,000 rpm built-in spindle , heavy duty roller linear guide ways and three axes linear scales achieve X, Y, Z, A, C 5 axes simultaneous accuracy. Complex shape machining, drilling, tapping, slanted machining, helical machining and intricate shape machining can be done easily.

Direct Driven Motor

A, C axes are all driven by DD motor, equipped with rotary encoder. Superior power transmission efficiency and energy saving than conventional worm gear design.

Built-in Spindle

Built-in high speed spindle can carry 100% power transmission, also the spindle is adapted with low noise and low spindle thermal expansion characteristics.

Heavy Load Table

High rigidity 800 × 800 mm rotation table support heavy table load up to 1,000 kgs gives you excellent cutting flexibility.

Symmetrical Hydraulic Brake System

Two sides of rotation table is adapted with circular hydraulic brake system to act in agile and efficient braking ability during heavy load and high speed rotation.

Rapid 3 Axes Feedrate

X / Y / Z axes rapid feedrate up to 48 m/min.

ATC Tool Changer

Arm type ATC with expandable tool capacity is located in the back side of machine. ATC design shorten tool waiting time.



(FMV-99 with Heidenhain iTNC 530)



(FMV-99 with optional accessories)

- ▶ Spindle and A / C axis cooling system and hydraulic system are all located within splash guard of machine. This compact design with large four pieces window provides easy maintenance accessibility.
- ▶ Standard ATC with 40 tools capacity and tool magazine control panel provides you excellent tool exchange efficiency. (80 tools capacity is also available)



Cooling System



40 - tool ATC



- ▶ Built-in large volume coolant tank and chip conveyor are located in inner side of machine. Reduce the floor space and provides good chips removal efficiency.

FMV-45 SERIES 5-AXIS MACHINING CENTER

FMV-45 keeps the advantage of FMV-99 design and further gives you wider table rotation range, and smaller floor space requirement. FMV-45 is suitable for medium and small size complex shape parts machining.

Direct Driven Motor

B, C axes are all driven by superior DD motor, equipped with rotary encoder. Superior power transmission efficiency and energy saving than conventional worm gear design.

Built-in Spindle

Built-in high speed spindle can carry 100% power transmission, also the spindle is adapted with low noise and low spindle thermal expansion characteristics.

Heavy Load Table

High rigidity design 400 × 400 mm rotation table support load up to 300 kgs gives you the ample cutting flexibility.

High Rigid Structure

The compact design, 3 points support girder and servo motor driven Y axis efficiently upgrade the axes movement accuracy and structure rigidity.

Rapid 3 Axes Feedrate

X / Y / Z axes rapid feedrate up to 48 m/min.

ATC Tool Changer

Arm type ATC with expandable tool capacity is located in the left side of machine. ATC design shorten tool waiting time.



(FMV-45 with Heidenhain iTNC 530)



(FMV 45 with optional accessories)

- ▶ Spindle and B / C axis cooling system and hydraulic system are all located within splash guard of machine. This compact design with large four pieces window design provides easier maintenance accessibility.
- ▶ Standard ATC with 40 tools capacity and tool magazine control panel provides you high tool exchange efficiency. (60 tools capacity is also available.)



Cooling System



40 - tool ATC



- ▶ Built-in large volume coolant tank and chip conveyor are located in inner side of machine. Reduce the floor space and provides good chips removal efficiency.

FMV SERIES HIGH RIGIDITY STRUCTURE

- ▶ Built to endure years and years of rigorous high production machining, the thermally balanced one piece design, U shaped high rigidity structure and casting components are of FC 300 Meehanite casting. FC300 grade cast iron is capable of withstanding much greater stress without deforming and provides maximum vibration dampening, which result in a machine that will outlast and outperform the competition.

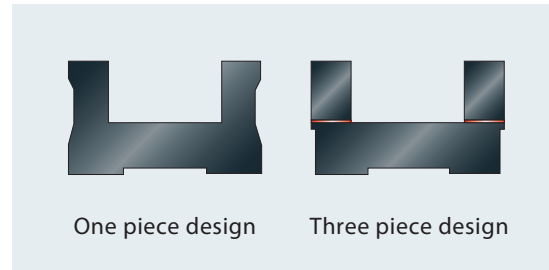

- ▶ Pre-pressed THK heavy duty roller linear guide way can efficiently eliminate clearance between slide block and guide way and prevent floating effect during axes movement at full speed. Hence, FMV provides both superior accuracy and stability at low cutting feed rate.
- ▶ C3 class hardened and precision grinded ball screws ensure the highest accuracy and durability possible. Plus, pretension on all axes minimizes thermal distortion.



(Casting structure of FMV-99 model shown)

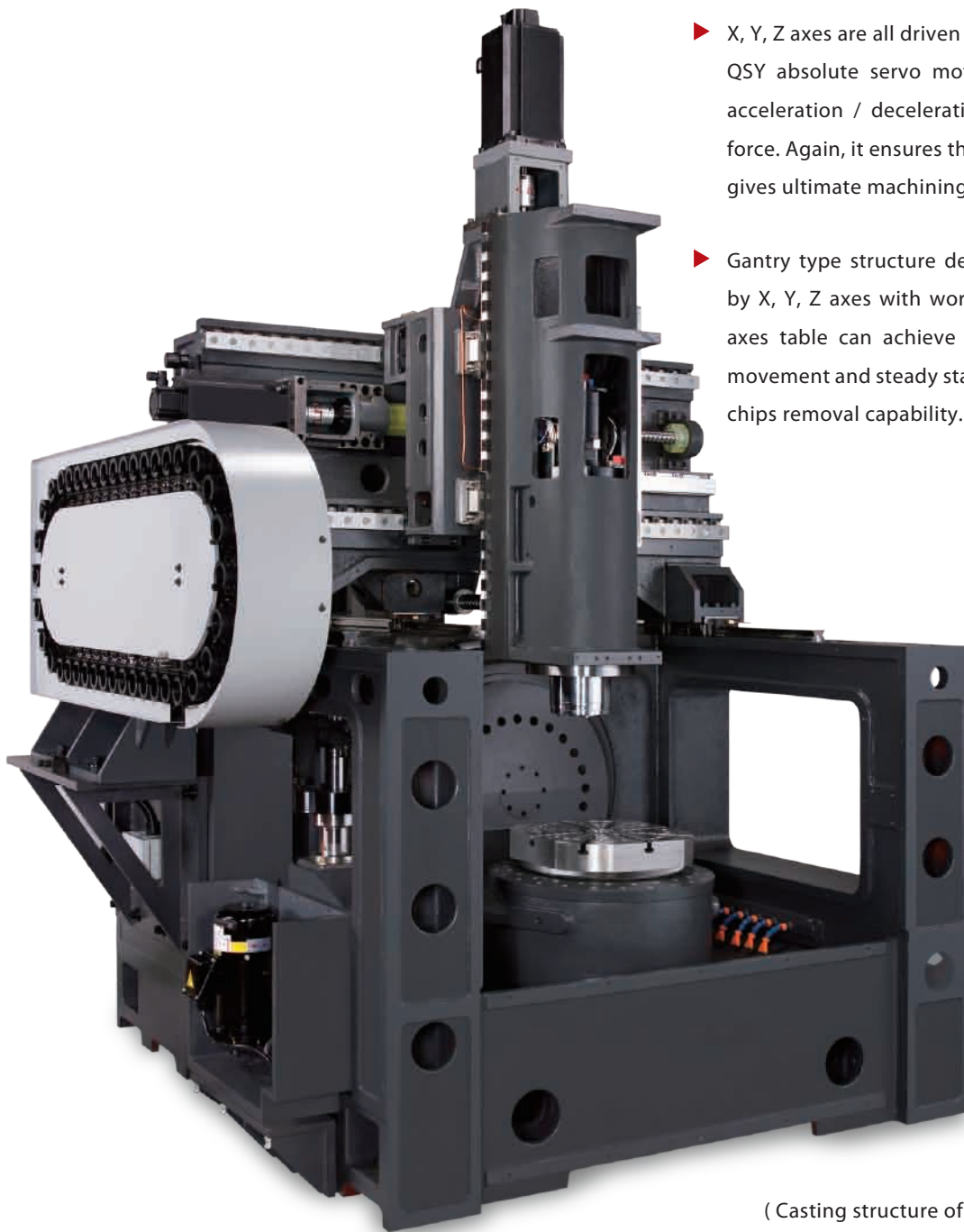

- ▶ X, Y, Z axes are all driven by superior Heidenhain QSY absolute servo motor, which gives faster acceleration / deceleration and powerful push force. Again, it ensures the cutting efficiency and gives ultimate machining power.
- ▶ Gantry type structure design, spindle is moved by X, Y, Z axes with work piece moved by A, C axes table can achieve high accuracy in both movement and steady status, also provide better chips removal capability.

(Casting structure of FMV-45 model shown)

Roller linear guide way, its linear-contact surface between guide way and slide block performs with much higher rigidity and higher load capacity than ball linear guide way, which is point-contact.

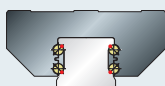

Ball type

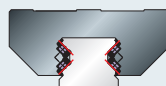

Roller type



FEM Analysis

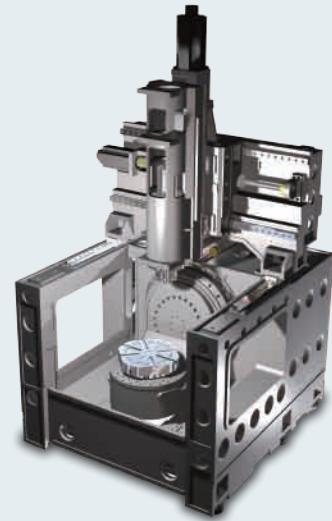
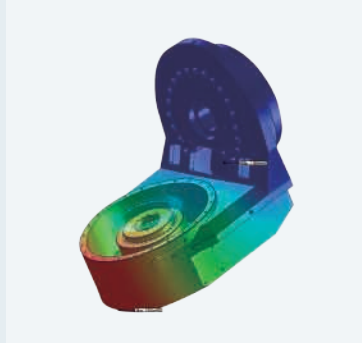
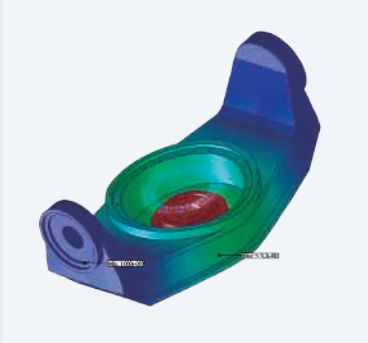

- ▶ Utilizing the Finite Element Method (FEM) analysis, optimal reinforced ribs are directly cast into the one-piece bed structure. The mechanical rigidity has been increased by more than 30% when compared to conventional design. Hence, the FMV series is capable of performing super heavy-duty machining and maintain long-term superior high-precision accuracy.

- ▶ Development in 3D CAD design and analysis can achieve the FEM structure in optimal design and compact rigid module.

Shortest Spindle Over-hang Distance

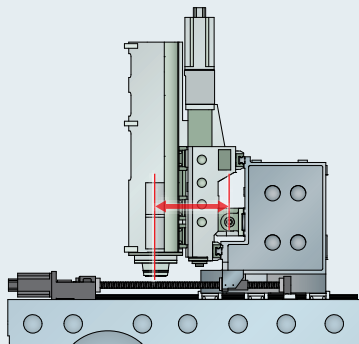

- ▶ Shortest spindle over-hang distance among comparable machines in the industry, provides required stiffness for heavy cutting.

Three Points Support

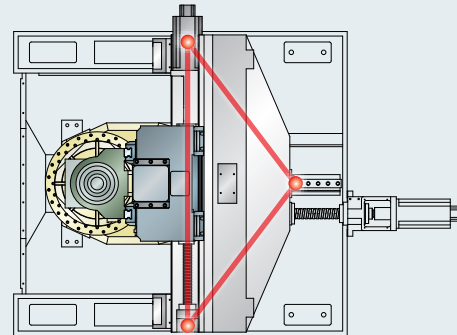

- ▶ Three points supported girder and THK roller linear guide way slide blocks give spindle headstock and saddle strong supports.



Precise Hand Scraping

- ▶ Contact surfaces of all slides, column, and ball screw bearing housing etc are all precisely hand scraped to provide maximum assembly precision, structural rigidity and load distribution. Furthermore, extensive skilled scraping induces maximum heavy cutting performance and machining accuracy.



High Performance Rotary Table

- ▶ FMV rotary table is in one-piece FCD structure which has advantages in better extension, anti-vibration capability than conventional material. Hence, FMV is capable of presenting high performance in heavy cutting and high speed machining.
- ▶ FMV rotation axes are driven by high speed, high torque, zero back lash DD motor, installed with rotary encoder. Superior power transmission and also saves energy consumption.

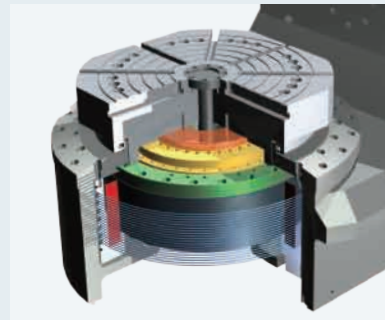

- ▶ Rotary table is adapted with circular hydraulic brake system. Circular hydraulic brake can fully lock 360° of table simultaneously. It's rigidity and heavy cutting character is superior than conventional disk brake and also circular hydraulic brake can avoid table deformation when locked in disk brake system.

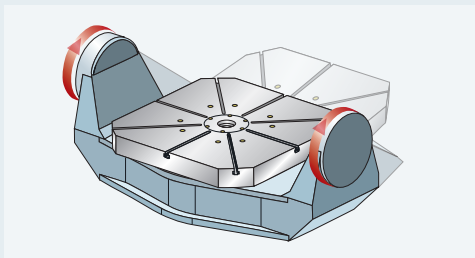

- ▶ FMV-99 rotary table is adapted with circular hydraulic brake system which ensures the reliable brake capability of heavy duty table in high speed rotation.

Easy Access

- ▶ Sufficient working space in FMV. By using gantry directly to load / unload work piece on table makes working process more efficiently.



FM-16V SERIES MULTI-FACE VERTICAL MACHINING CENTER

Based on compact design of FM-16 gantry type high speed machining center, FM-16V adapts 15,000 rpm direct drive spindle, integrated with NC titling rotary table into 4+1 axes and high speed & multi-face machining center. FM-16V gives you much more convenience in multi-face machining in single procedure, and it's easy access for slanted machining at any angle without manually turning work piece.

High Rigidity Gantry Type Structure

Compact design with gantry type one-piece column & bridge, and wider T shape saddle gives the strong basis for heavy cutting.

Powerful Spindle

Direct high speed spindle 15,000 rpm as a standard. Optional higher speed direct spindle and built-in spindle are available, maximum to 22,000 rpm.

NC Titling Rotary Table

A / C axes NC titling rotary table, it's A axes titling angle from +30° to -120° and minimum indexing at 0.001° for A / C axes table can sustain cutting force to 70 N-m.

High Quality Critical Components

Precision ball screw and heavy duty roller linear guide way on three axes. Z axis is supported by 6 strong linear blocks. This compact design gives spindle sufficient support.



(FM-16V with optional accessories)

► X / Y / Z axes are driven by Fanuc alpha *i* series absolute AC servo motor, which provides tremendous thrust outputs with faster acceleration and deceleration. Absolute Coordinate technology does not need machine adapted with limit switch. Hence, axes do not need return to the original after power on.

► Standard drum type ATC with 20 tools capacity is located on the left side of machine. ATC tool exchange is faster and easy for maintenance.

► Z axis slide is supported by 6 strong linear blocks.

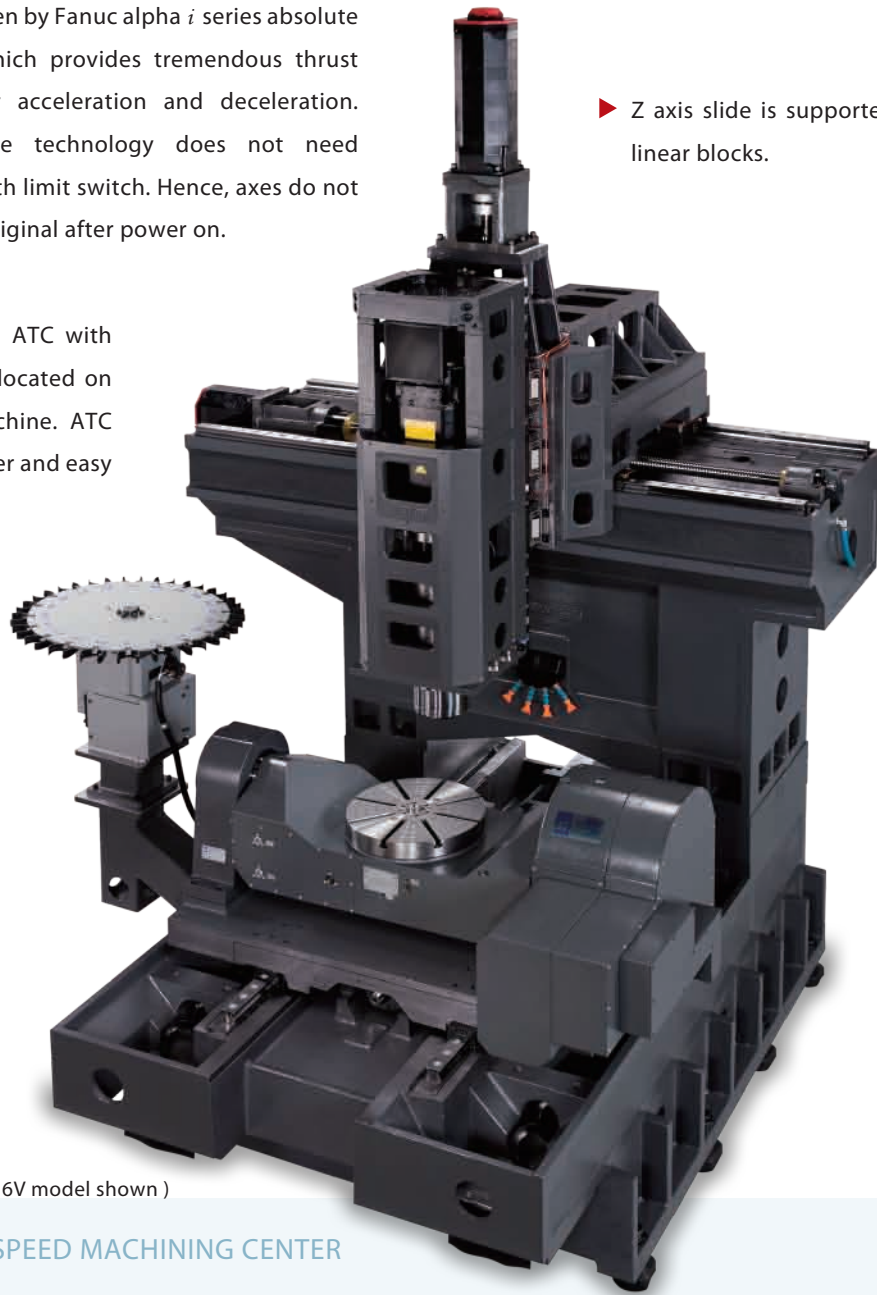

(Casting structure of FM-16V model shown)

FM SERIES HIGH SPEED MACHINING CENTER



FM-16



FM-7



FM-87



FM-101

ULTIMATE MACHINING POWER

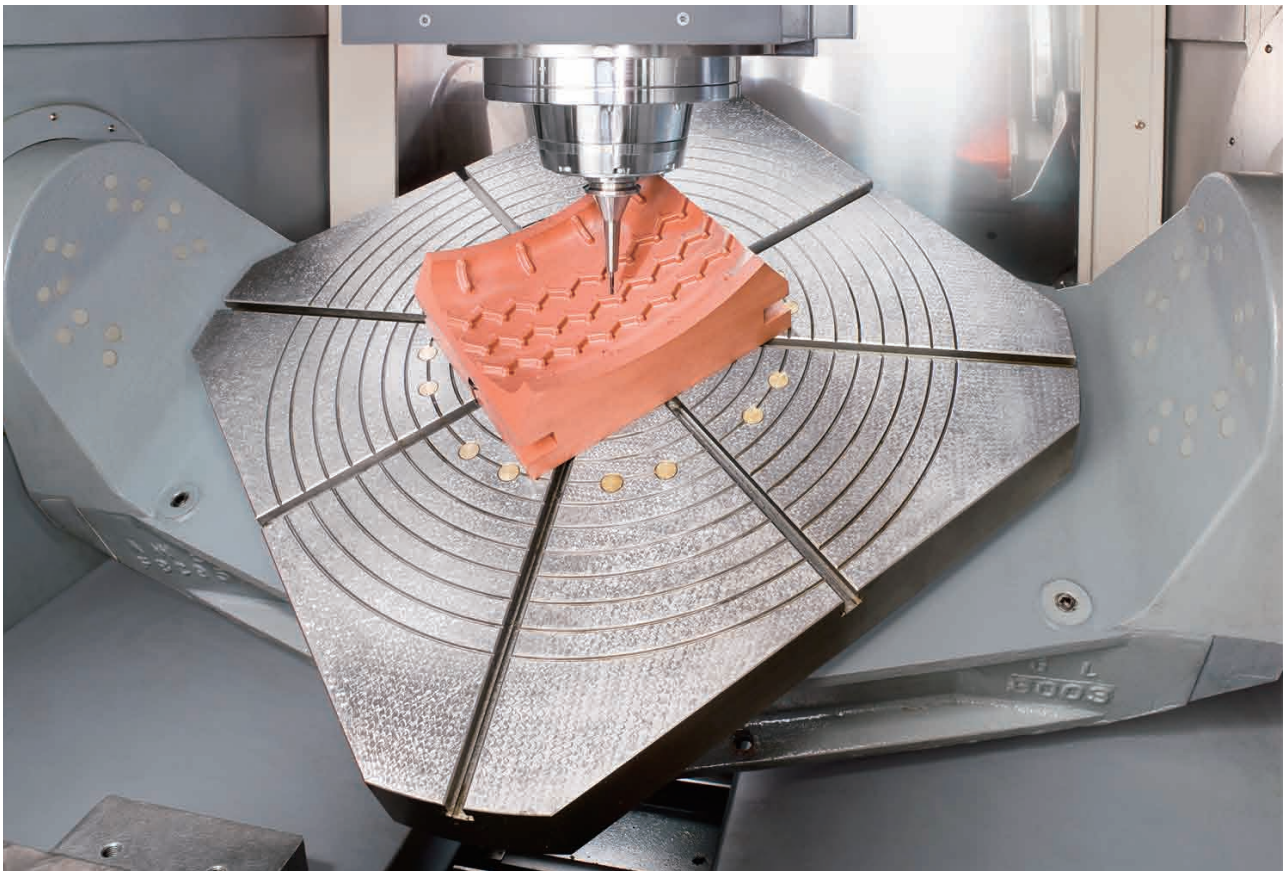

MACHINING CAPACITY – FMV-45 SERIES

material: S45C

	Tools (mm)	Spindle Speed (rpm)	Feedrate (mm)	Depth of Cut (mm)	Width of Cut (mm)	Feed Rate/Blade (mm)	Spindle Load (%)
High Speed Drill	Ø 30	1,200	144	20	–	0.12	91
Tapping	M33*3.5	50	175	20	–	–	–
Heavy Cutting	Ø 50	2,000	8,000	1.5	32	0.8	68

MACHINING CAPACITY – FMV-99 SERIES

material: S45C

	Tools (mm)	Spindle Speed (rpm)	Feedrate (mm)	Depth of Cut (mm)	Width of Cut (mm)	Feed Rate/Blade (mm)	Spindle Load (%)
High Speed Drill	Ø 40	1,000	130	20	–	0.13	96
Tapping	M42*4.5	50	225	20	–	–	–
Heavy Cutting	Ø 50	2,000	10,000	1	32	1	74

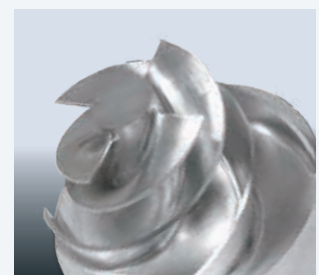
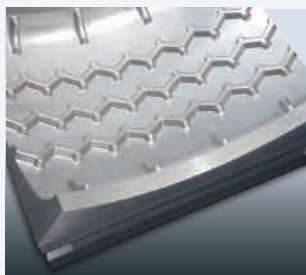



- ▶ Based on ISO1940 standard, high speed spindle is performed with dynamic balance test in environment controlled area to ensure spindle stability.
- ▶ Spindle is adapted high precision P4 ceramic bearing can endure heavy dynamic loading. The position of bearings fit in optimal two-points span design and can fulfill stable heavy cutting and long-term precise cutting requirement.

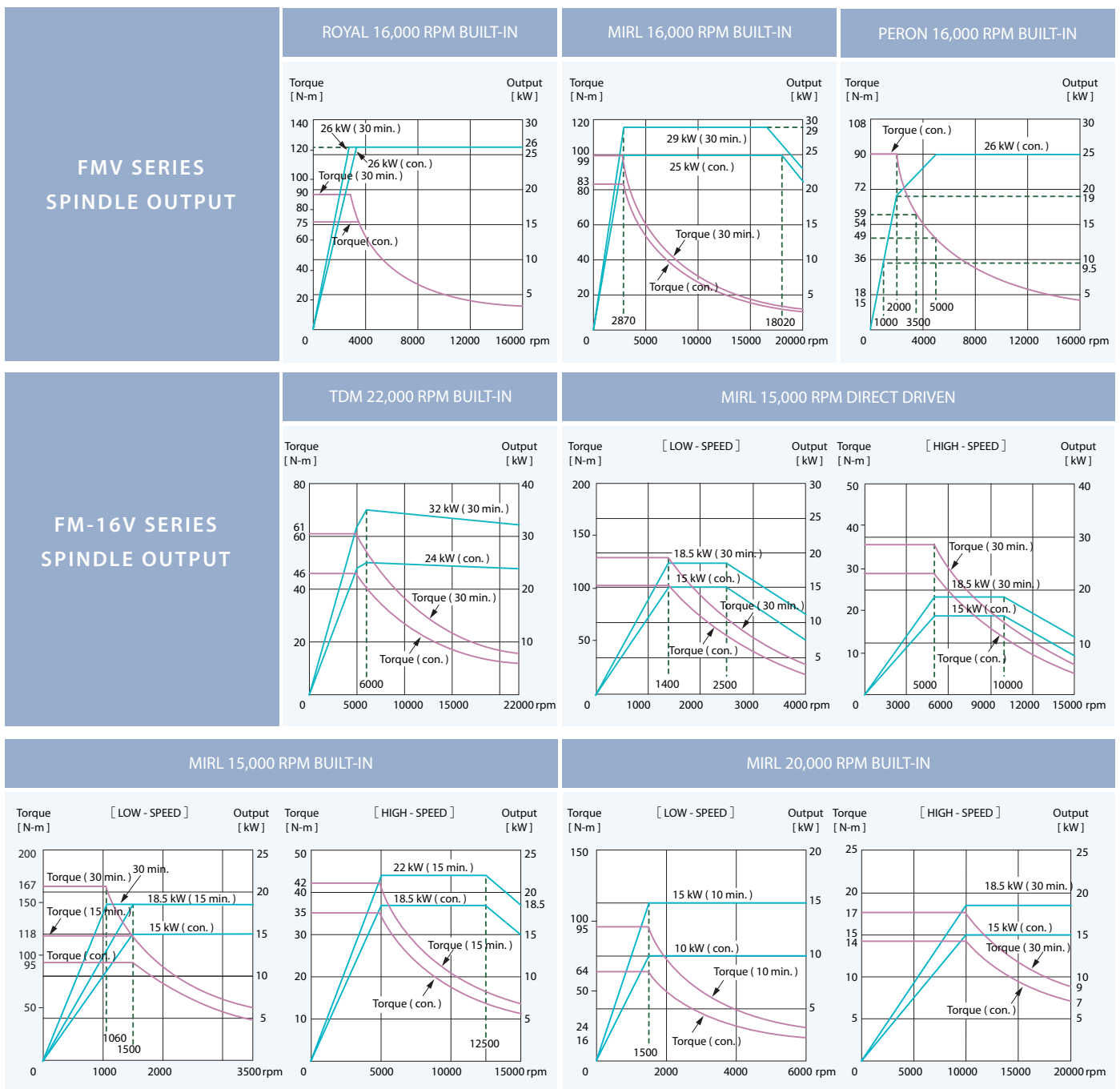

DIMENSIONS

MACHINE SPACE REQUIREMENT

FMV-99 SERIES

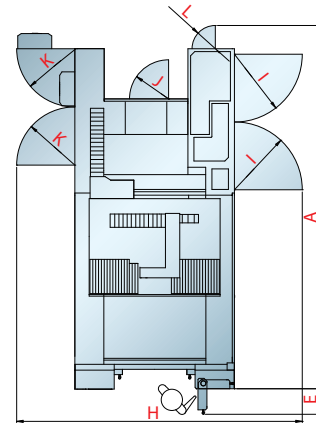
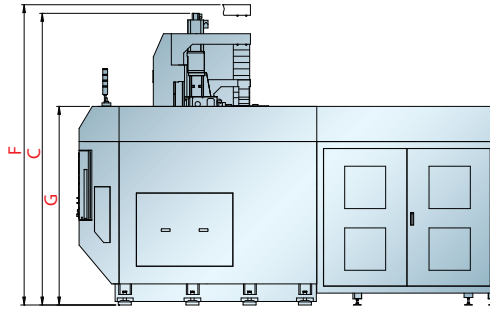
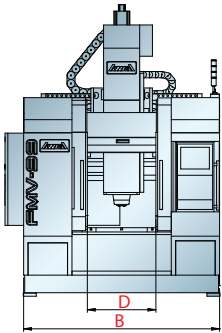

(Unit : mm)

Models	A	B	C	D	E	F	G	H	I	J	K	L
FMV-99	5,076	2,230	3,320	900	357	3,420	2,260	4,000	948	546	813	325

FMV-45 SERIES

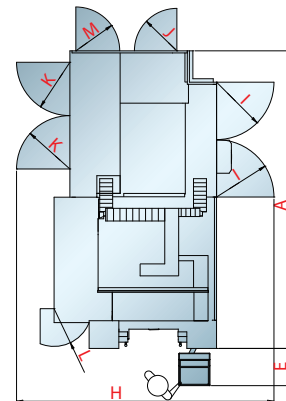
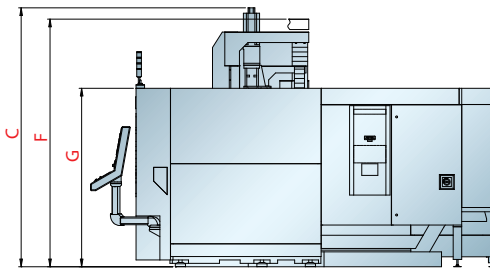
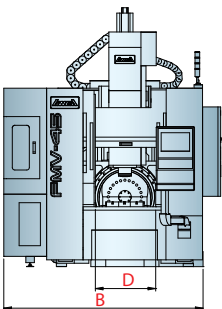

(Unit : mm)

Models	A	B	C	D	E	F	G	H	I	J	K	L	M
FMV-45	4,280	2,340	3,040	700	535	2,910	2,100	3,700	825	610	767	542	630

FM-16V SERIES

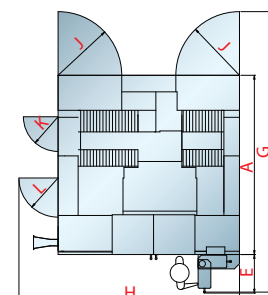
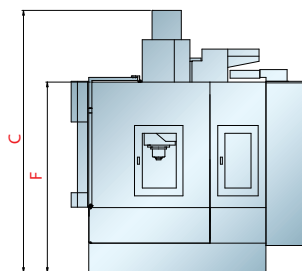
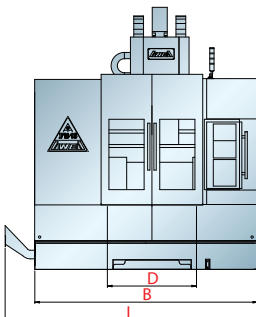

(Unit : mm)

Models	A	B	C	D	E	F	G	H	I	J	K	L
FM-16V	2,820	2,850	3,360	1,140	605	2,435	4,400	3,465	3,230	1,000	545	615

Specifications are subject to change without notice.

TABLE DIMENSION

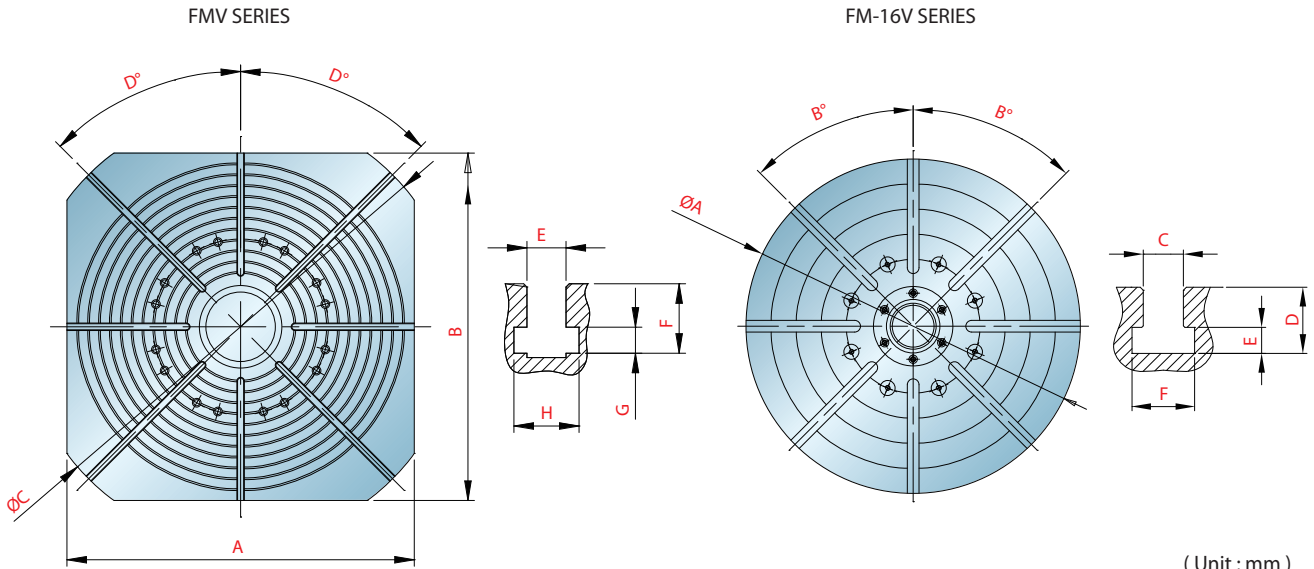

(Unit : mm)

Models	A	B	C	D	E	F	G	H
FMV-45	400	400	450	45	14	25	9	24
FMV-99	800	800	900	45	14	25	9	24
FM-16V	400	45	12H7	20	8	19	-	-

FMV-99 SERIES

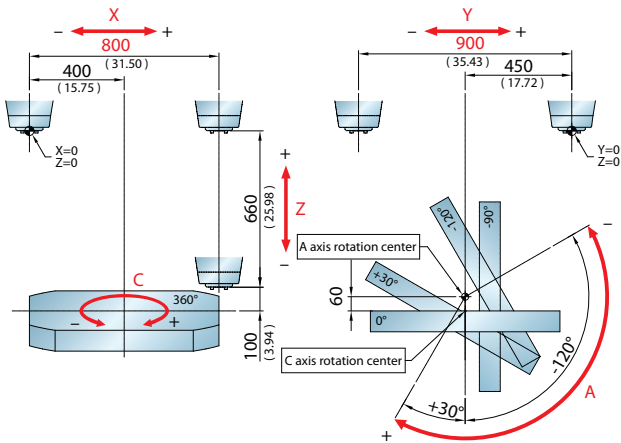

FMV-45 SERIES

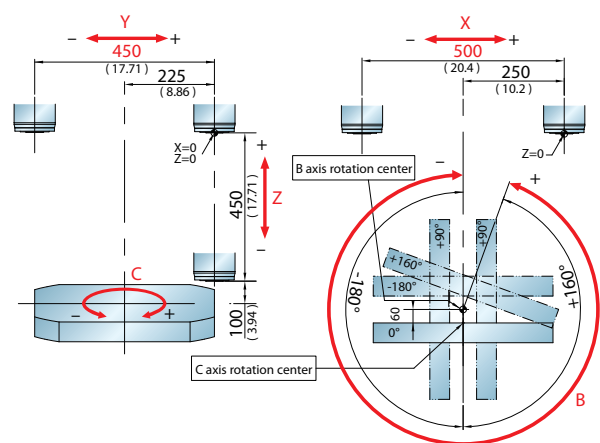

WORKPIECE DIMENSION

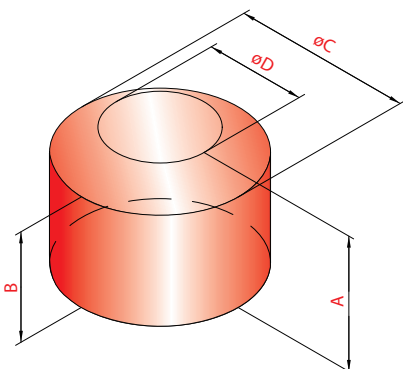

Models	Unit	A	B	C	D	Max. load
FMV-45	mm	450	400	400	300	300 Kg
FMV-99	mm	600	490	800	450	1,000 Kg
FM-16V	mm	400	350	400	300	200 Kg

Specifications are subject to change without notice.

FEATURES & QUALITY

FEATURES

A/C Cooling System



Spindle Coolant



Oil Coolant System



Linear Scale On X / Y / Z



Coolant Through Spindle



ATLM



For more detail accessories, please refer to p18. Specification list & or contact AWEA.

STRICT QUALITY ASSURANCE

3D Measuring



Laser Inspection



Workpiece Cutting Test



Ball Bar Inspection



Precision Grinder



- ▶ Test cutting must fulfill strict German VDI 3441 (average the statics after repeating 5 times traverse back and forth)
- ▶ Critical components, such as rotary table, is machined in SUMITOMO high precision Vertical Grinding machine.

MACHINE SPECIFICATIONS

Models	FM-99 High spd. series	FMV-99 5-axis series	FM-45 High spd. series	FMV-45 5-axis series	FM-16V multi-face series
X-axis travel (left - right)	900 mm	800 mm	600 mm	500 mm	500 mm
Y-axis travel (front - back)	900 mm		450 mm		400 mm
Z-axis travel (up - down)	660 mm		450 mm		400 mm
Spindle nose to table	150 ~ 810 mm	110 ~ 760 mm	100 ~ 550 mm		100 ~ 500 mm
Max. spindle speed	built-in 16,000 rpm		built-in 16,000 rpm		direct driven 15,000 rpm
Spindle taper	BT 40		BT 40 / HSK A63		BT 40
Spindle motor output	26 kW (con. / 30min)		25 / 29 kW (con. / 30min)		15 / 18.5 kW (con. / 30min)
Cutting feedrate	24 m/min		24 m/min		20 m/min
X / Y / Z axes rapids	48 m/min		48 m/min		30 m/min
Table size (X × Y)	1,060 × 900 mm	Ø 900 mm ; 800 × 800 mm	800 × 450 mm	Ø 450 mm ; 400 × 400 mm	Ø 400 mm
T slot	14 × 9 × 100 mm	14 mm × 8 mm × 45°	14 × 8 × 80 mm	14 mm × 8 mm × 45°	14H7 mm
Max. table load	2,500 Kg	1,000 Kg	1,000 Kg	300 Kg	200 Kg (0°~45°)
Swiveling range of A / B axes	–	A-axis : -120° / +30°	–	B-axis : -180° / +160°	A-axis : -120° / +30°
Rotary ranfe of C-axis	–	360°	–	360°	360°
Swiveling speed of A / B axes	–	A-axis : 30 rpm	–	B-axis : 30 rpm	A-axis : 8.3 rpm
Rotary speed of C-axis	–	100 rpm	–	100 rpm	16.7 rpm
ATC Type	Arm type		Arm type		Drum type
Tool magazine capacity	40 Station (80 Opt.)		40 Station (60 Opt.)		20 Station
Max. tool diameter / adjacent	Ø 90 / 125 mm		Ø 75 mm		Ø 80 mm
Max. tool length	300 mm		250 mm		300 mm
Max. tool weight	8 Kg		6 Kg		7 Kg
CNC control	Heidenhain iTNC 530		Heidenhain iTNC 530		Fanuc 18i - MB
Coolant tank capacity	500 L		500 L		360 L
Air requirement	6 Kg/cm ²		6 Kg/cm ²		7 Kg/cm ²
Power requirement	65 KVA	90 KVA	65 KVA	80 KVA	55 KVA
Machine weight	13,000 Kg	15,000 Kg	10,000 Kg	11,500 Kg	11,500 Kg
Dimensions (L × W × H)	4,530 × 2,230 × 3,420 mm		4,280 × 2,340 × 3,040 mm		3,050 × 2,850 × 3,360 mm

STANDARD & OPTIONAL FEATURES

S : Standard O : Option
 – : Not Available C : Contact Awea

Models		FM-99	FMV-99	FM-45	FMV-45	FM-16V
Chip Conveyor	Steelbelt Type	S	S	S	S	O
	Scraper Type	O	O	O	O	O
ATLM		O	O	O	O	O
Dust Collecting System		O	O	O	O	O
Oil Skimmer		O	O	O	O	O
Oil Mist Collector		O	O	O	O	O
Oil Mist Lubrication System		O	O	O	O	O
A/C Cooling System		S	S	S	S	O
Oil Coolant System		O	O	O	O	O
Coolant Through Spindle System		O	O	O	O	O
Linear Scale On X / Y / Z		O	S	O	O	O

Specifications are subject to change without notice.



THE ULTIMATE MACHINING POWER

AWEA MECHANTRONIC CO., LTD.

HEADQUARTERS

629, Suezhetou Section, kwanpu Rd.,

Wenshan Li, Hsinpu Town,

Hsinchu County 305, Taiwan

TEL : +886-3-588-5191

FAX : +886-3-588-5194

CENTRAL TAIWAN SCIENCE PARK BRANCH

15, Keyuan 2nd Rd.,

Central Taiwan Science Park,

Taichung City 407, Taiwan

TEL : +886-4-2462-9698

FAX : +886-4-2462-8002

Website : www.awea.com

E-mail : sales@awea.com